

1	2	3	4
RevNr.	Änderungsindex	Datum	Visum
			Geprüft

A

A

B

B

C

C

D

D

E

E

F

F

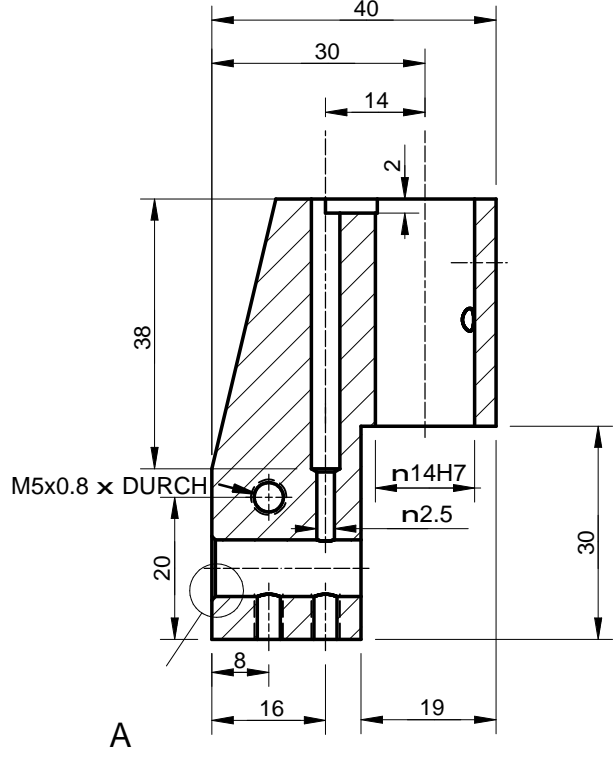
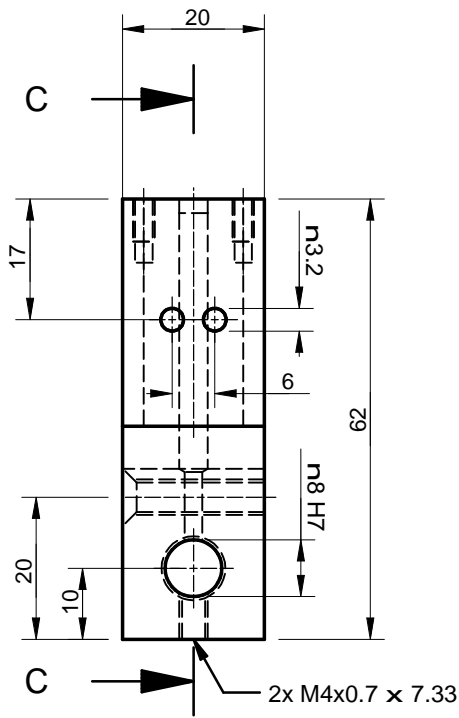

Schnitt C-C

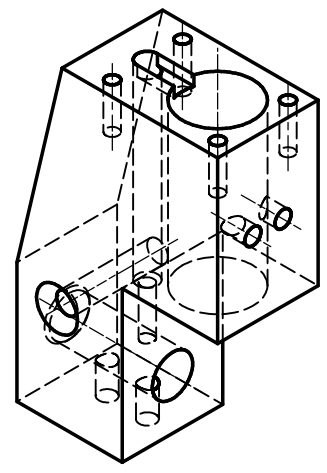
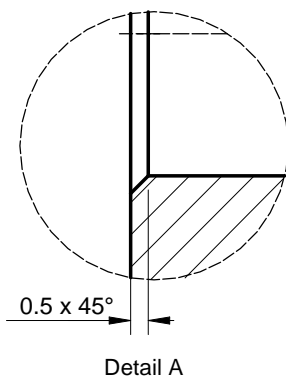
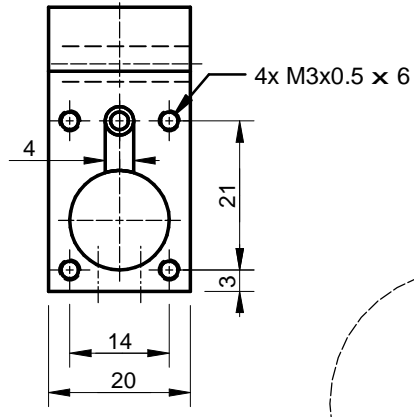

Pos.	Menge	Benennung	Sachnummer
Gezeichnet von AHu1	Geprüft von	Geprüft am	Dateiname
			Datum 19.04.2004
			Maßstab
		Motorblock	
		DLM-003	Version Blatt-Nr.

1	2	3	4
RevNr.	Änderungsindex	Datum	Visum
			Geprüft

A

A

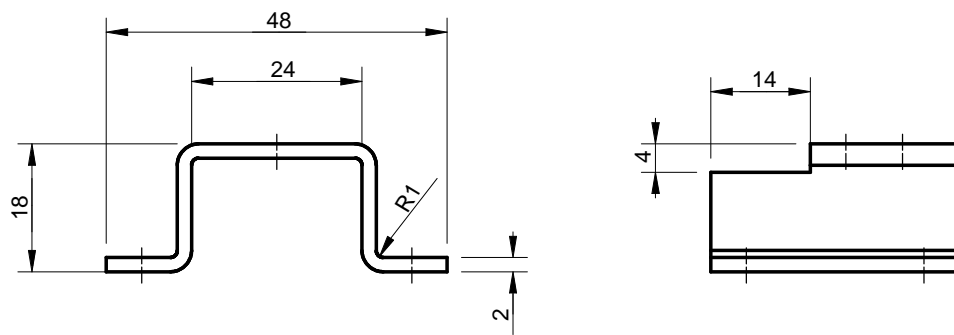

B

B

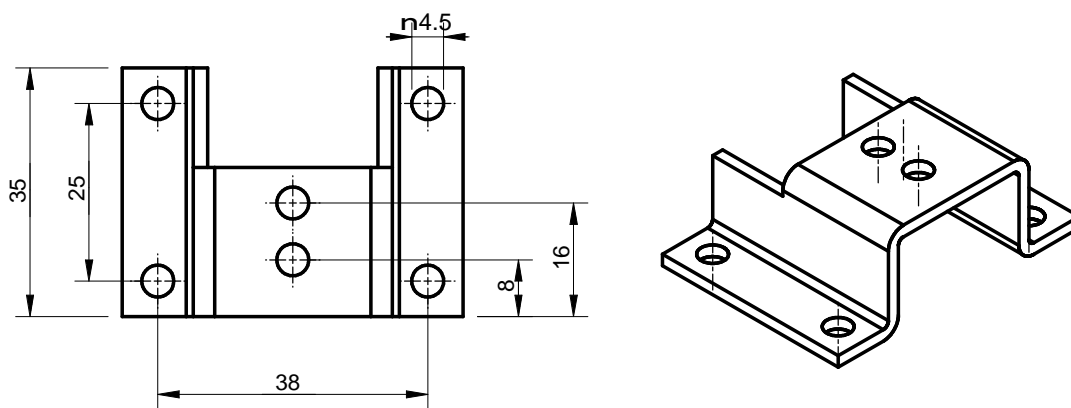

C

C

D

D

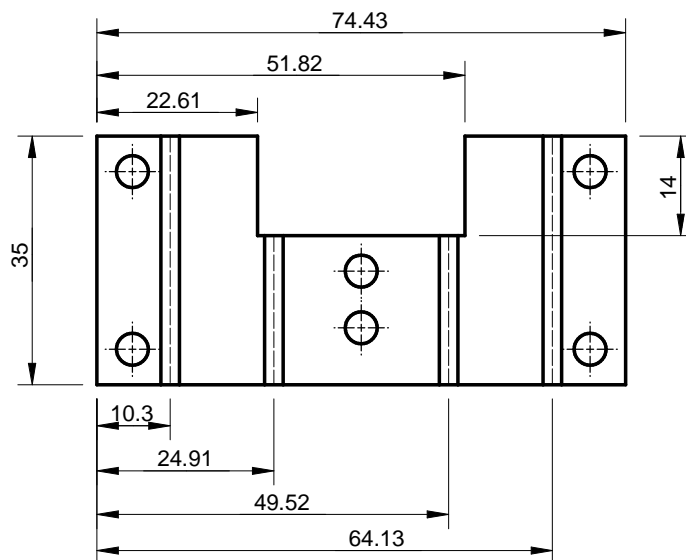

E

E

F

F

Pos.	Menge	Benennung			Sachnummer	
Gezeichnet von AHu1	Geprüft von	Geprüft am	Dateiname	Datum 19.04.2004	Maßstab	
			Befestigungsbügel			
			DLM-002			Version

1

4

1	2	3	4
RevNr.	Änderungsindex	Datum	Visum
			Geprüft

A

A

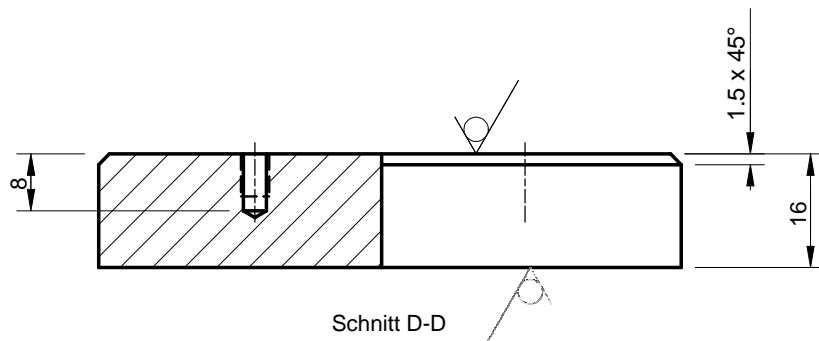

B

B

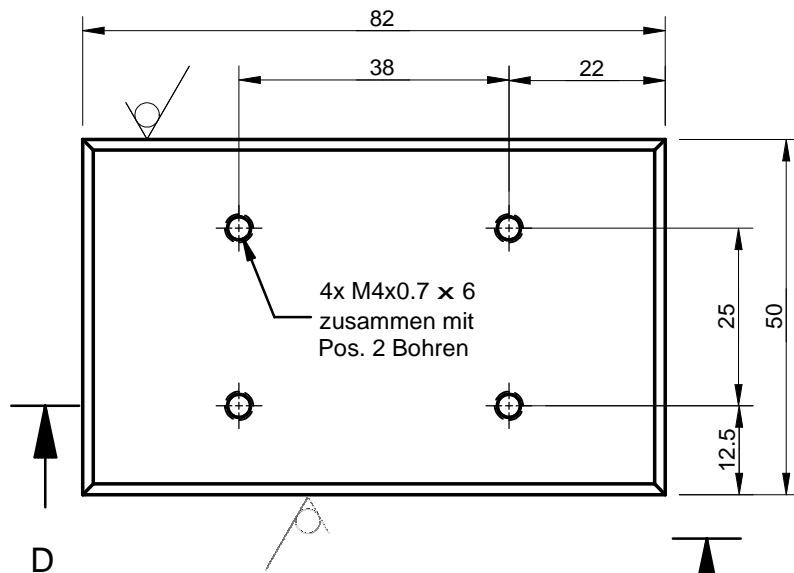

C

C

D

D

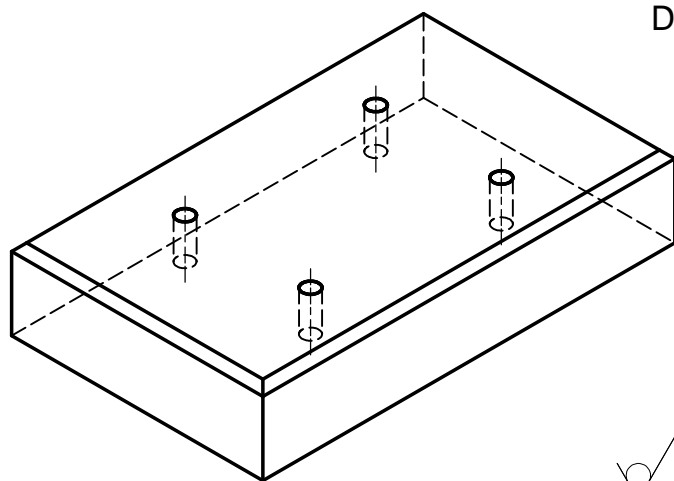

E

E

F

F

Pos.	Menge	Benennung	Sachnummer	
Gezeichnet von AHu1	Geprüft von	Geprüft am	Dateiname	Datum 19.04.2004
			Maßstab	
			Version	
			Blatt-Nr.	

Grundplatte

DLM-001

1

4

1	2	3	4
RevNr.	Änderungsindex	Datum	Visum
		Geprüft	

A

A

B

B

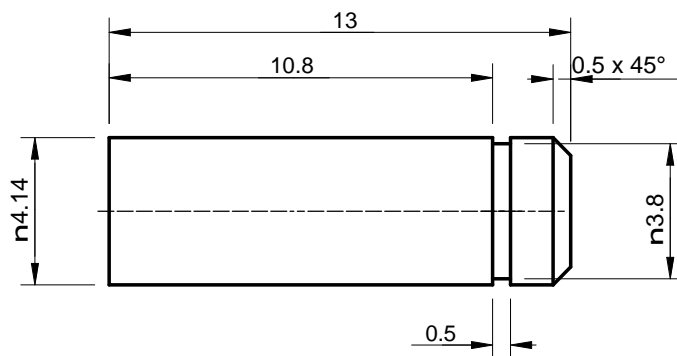

C

C

D

D

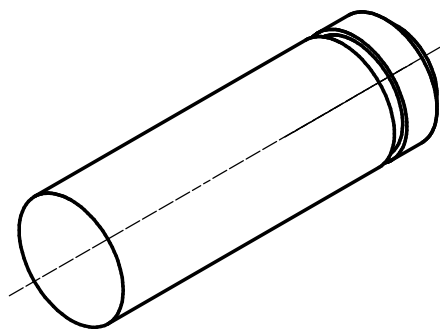

E

E

F

F

Pos.	Menge	Benennung	Sachnummer
Gezeichnet von AHu1	Geprüft von	Geprüft am	Dateiname
		Datum 19.04.2004	Maßstab
		Kurbelzapfen	
		DLH-009	Version
			Blatt-Nr.

1

4

A
B
C
D
E
F

A
B
C
D
E
F

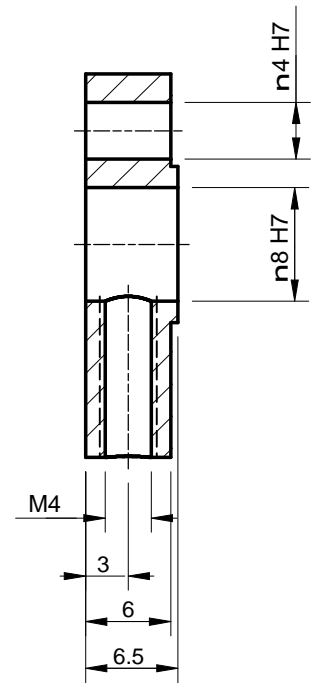
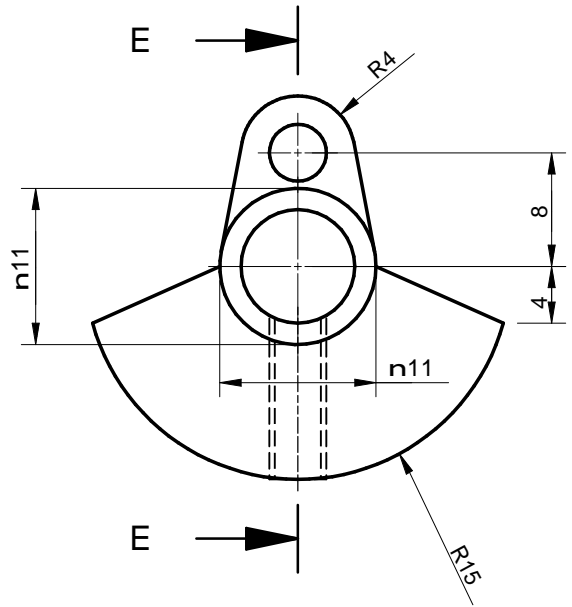

Schnitt E-E

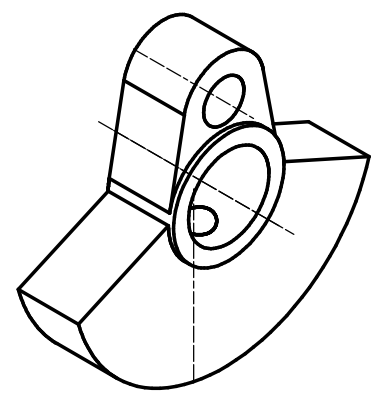

Pos.	Menge	Benennung	Sachnummer
Gezeichnet von AHu1	Geprüft von	Geprüft am	Dateiname Datum 19.04.2004 Maßstab
Kurbel			Version Blatt-Nr.
DLM-008			

1	2	3	4
RevNr.	Änderungsindex	Datum	Visum
		Geprüft	

A

A

B

B

C

C

D

D

E

E

F

F

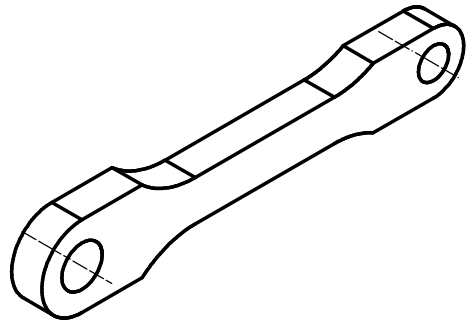
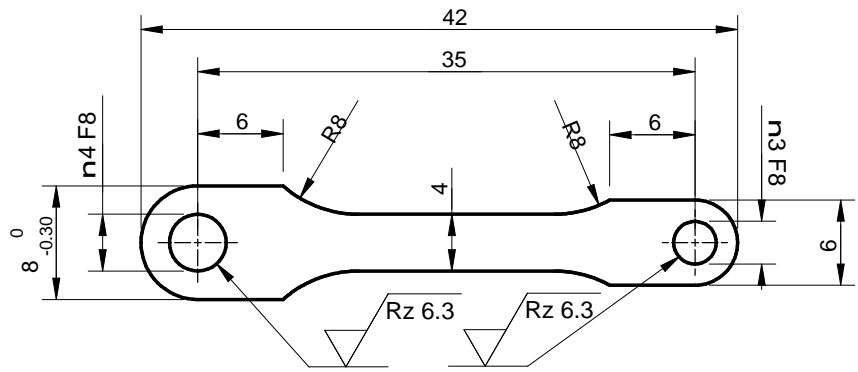

Pos.	Menge	Benennung	Sachnummer
Gezeichnet von AHu1	Geprüft von	Geprüft am	Dateiname
		Datum 19.04.2004	
		Maßstab	
		Pleuel	
		DLHM-010	Version
			Blatt-Nr.

1	2	3	4
RevNr.	Änderungsindex	Datum	Visum
			Geprüft

A

A

B

B

C

C

D

D

E

E

F

F

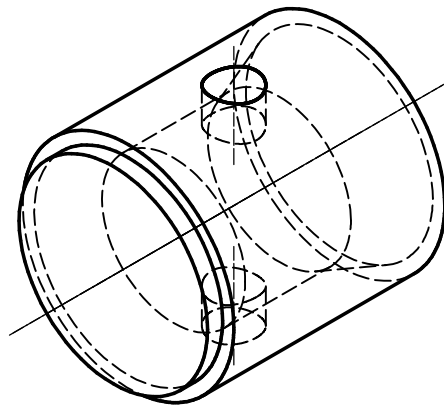
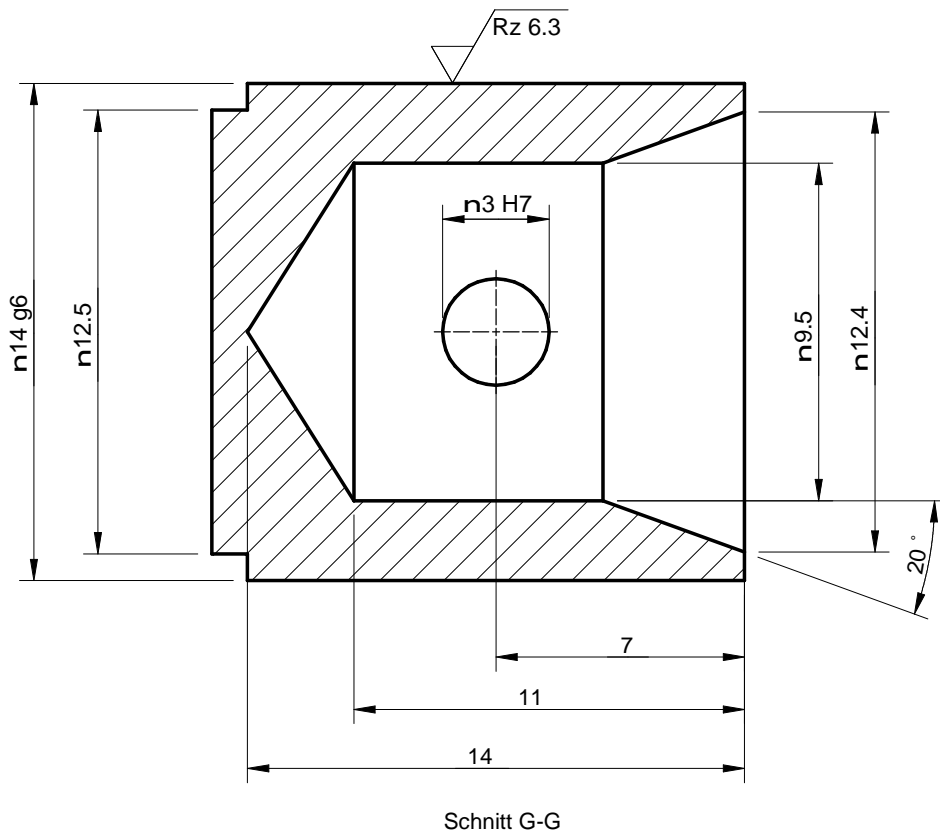

Pos.	Menge	Benennung	Sachnummer
Gezeichnet von AHu1	Geprüft von	Geprüft am	Dateiname
			Datum 19.04.2004
			Maßstab
		Kolben	
		DLM-011	Version
			Blatt-Nr.

1

4

1	2	3	4
RevNr.	Änderungsindex	Datum	Visum Geprüft

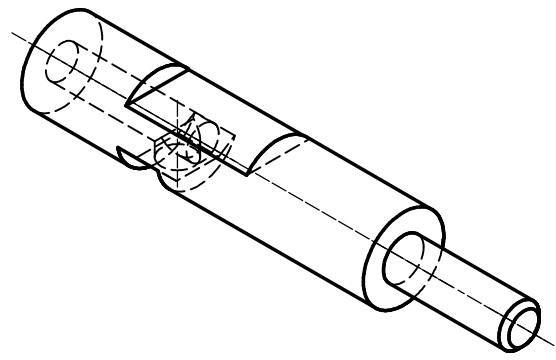
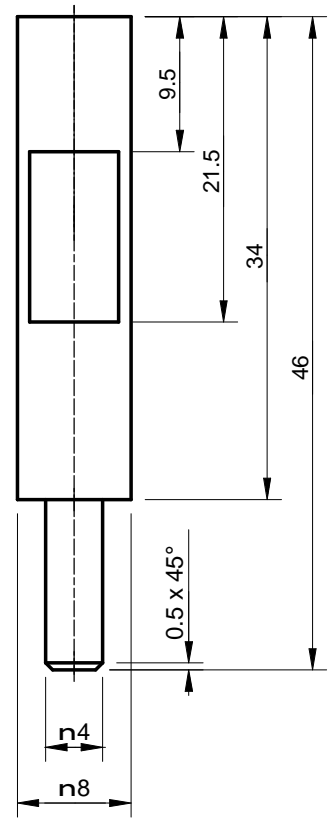
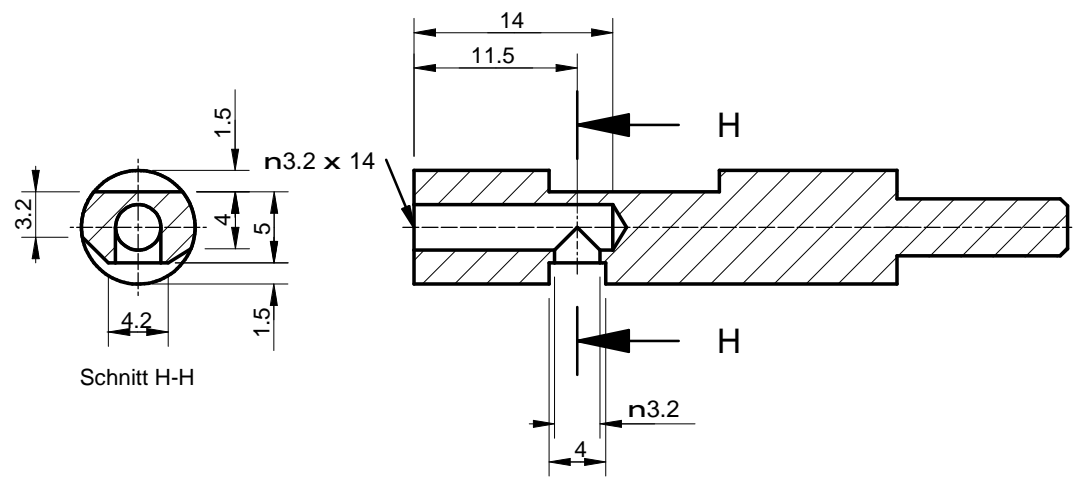

Pos.	Menge	Benennung			Sachnummer	
Gezeichnet von AHu1	Geprüft von	Geprüft am	Dateiname	Datum 20.04.2004	Maßstab	
<h1>Kurbelwelle</h1>				Version		Blatt-Nr.
				DLM-007		

1	2	3	4
RevNr.	Änderungsindex	Datum	Visum
			Geprüft

A

A

B

B

C

C

D

D

E

E

F

F

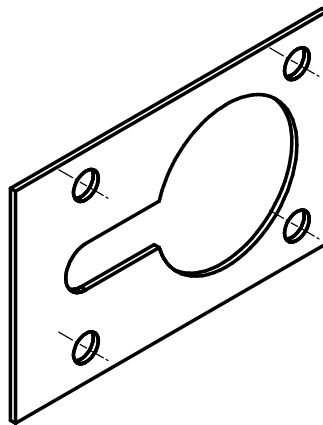
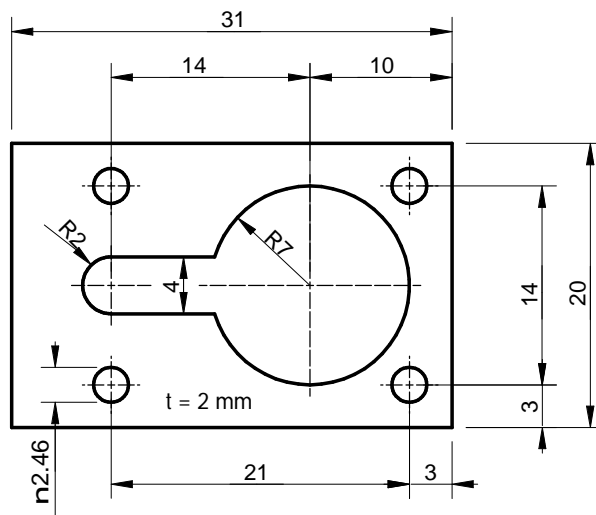

Pos.	Menge	Benennung	Sachnummer
Gezeichnet von AHu1	Geprüft von	Geprüft am	Dateiname
			Datum 20.04.2004
			Maßstab
		Zylinderkopfdichtung	
		DLM-004	Version
			Blatt-Nr.

1

4

A
B
C
D
E
F

A
B
C
D
E
F

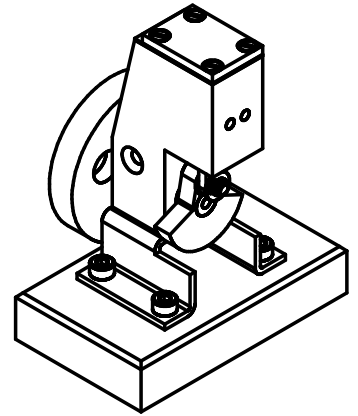
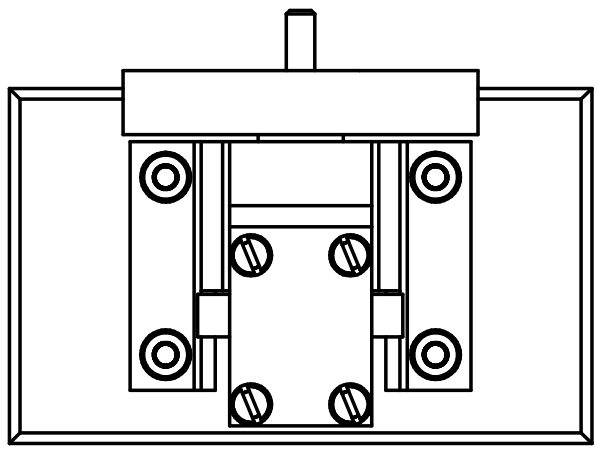
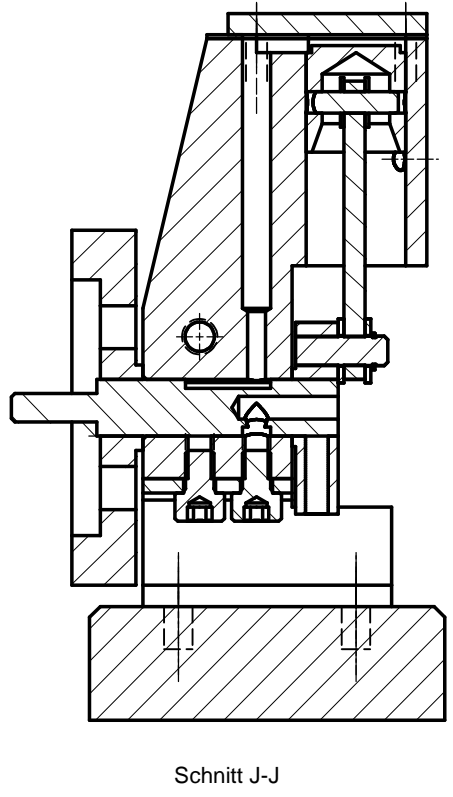
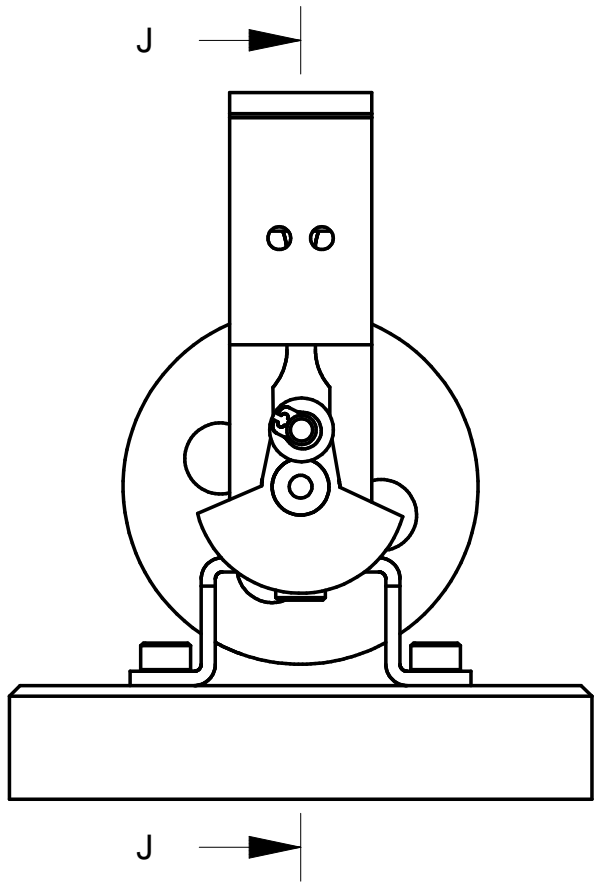

Pos.	Menge	Benennung	Sachnummer
Gezeichnet von AHu1	Geprüft von	Geprüft am	Dateiname
		Datum 20.04.2004	Maßstab
Druckluftmotor			
DLM_000		Version	Blatt-Nr.